

<b>TRADEMARK ASSIGNMENT COVER SHEET</b>
---

Electronic Version v1.1  
 Stylesheet Version v1.2

ETAS ID: TM374168

<b>SUBMISSION TYPE:</b>	NEW ASSIGNMENT		
<b>NATURE OF CONVEYANCE:</b>	ASSIGNMENT OF THE ENTIRE INTEREST AND THE GOODWILL		
<b>CONVEYING PARTY DATA</b>			
<b>Name</b>	<b>Formerly</b>	<b>Execution Date</b>	<b>Entity Type</b>
AU Merrow <i>Corporation</i>		02/22/2016	CORPORATION: CALIFORNIA
<b>RECEIVING PARTY DATA</b>			
<b>Name:</b>	ZZ Fashion <i>Corporation</i>		
<b>Doing Business As:</b>	Daniel Rainn/Black Rainn/Black Rainn by Daniel Rainn/pale sky		
<b>Street Address:</b>	7210 Dominion Circle		
<b>City:</b>	Commerce		
<b>State/Country:</b>	CALIFORNIA		
<b>Postal Code:</b>	90040		
<b>Entity Type:</b>	CORPORATION: CALIFORNIA		
<b>PROPERTY NUMBERS Total: 4</b>			
<b>Property Type</b>	<b>Number</b>	<b>Word Mark</b>	
<b>Registration Number:</b>	3913098	DANIEL RAINN	
<b>Registration Number:</b>	4214327	BLACK RAINN	
<b>Registration Number:</b>	4117691	BLACK RAINN BY DANIEL RAINN	
<b>Registration Number:</b>	4028693	PALE SKY	
<b>CORRESPONDENCE DATA</b>			
<b>Fax Number:</b>	2136278865		
<i>Correspondence will be sent to the e-mail address first; if that is unsuccessful, it will be sent using a fax number, if provided; if that is unsuccessful, it will be sent via US Mail.</i>			
<b>Phone:</b>	323-480-8835		
<b>Email:</b>	vincent@danielrainn.com		
<b>Correspondent Name:</b>	Vincent Peng		
<b>Address Line 1:</b>	7210 Dominion Circle		
<b>Address Line 4:</b>	Commerce, CALIFORNIA 90040		
<b>NAME OF SUBMITTER:</b>	Mandy Wang		
<b>SIGNATURE:</b>	/Mandy Wang/		
<b>DATE SIGNED:</b>	02/23/2016		
<b>Total Attachments: 27</b>			
source=Daniel Rainn#page1.tif			

OP \$115.00 3913098

source=Daniel Rainn#page2.tif  
source=Black Rainn#page1.tif  
source=Black Rainn#page2.tif  
source=Black Rainn by Daniel Rainn#page1.tif  
source=Black Rainn by Daniel Rainn#page2.tif  
source=pale sky#page1.tif  
source=pale sky#page2.tif  
source=Customer Order#page1.tif  
source=Customer Order#page2.tif  
source=Customer Order#page3.tif  
source=Customer Order#page4.tif  
source=Customer Order#page5.tif  
source=Customer Order#page6.tif  
source=Customer Order#page7.tif  
source=Customer Order#page8.tif  
source=Customer Order#page9.tif  
source=Customer Order#page10.tif  
source=Customer Order#page11.tif  
source=Customer Order#page12.tif  
source=Customer Order#page13.tif  
source=Customer Order#page14.tif  
source=Customer Order#page15.tif  
source=Customer Order#page16.tif  
source=Customer Order#page17.tif  
source=Customer Order#page18.tif  
source=Customer Order#page19.tif

## ASSIGNMENT OF PATENT

Whereas, Jianhua Zhu (As Known as: Mandy Wang) who's the owner of AU MERROW CORPORATION (Assignor), has used and is using a mark which is registered in the United States Patent and Trademark Office, Registration No. 3913098 dated Feb. 1, 2011. Which mark is known as Daniel Rainn.

Whereas, Mandy Wang (Formerly Known as: Jianhua Zhu) who's the owner of ZZ Fashion Corporation (Assignee), desires to acquire such mark and the registration thereof:

Now, Therefore, for good and valuable consideration, receipt of which is hereby acknowledged, the Assignor does hereby assign to Assignee all rights, title and interest in and to the mark described herein, together with the good will of the business symbolized by such mark, in the above identified registration thereof.

[ASSIGNOR]

Executed this: 02-22-2016

By: AU MERROW CORPORATION

OWNER Name: Jianhua Zhu

Signature: 

## ASSIGNMENT OF PATENT

Whereas, Jianhua Zhu (As Known as: Mandy Wang) who's the owner of AU MERROW CORPORATION (Assignor), has used and is using a mark which is registered in the United States Patent and Trademark Office, Registration No. 4214327 dated Sep. 25, 2012. Which mark is known as Black Rainn.

Whereas, Mandy Wang (Formerly Known as: Jianhua Zhu) who's the owner of ZZ Fashion Corporation (Assignee), desires to acquire such mark and the registration thereof:

Now, Therefore, for good and valuable consideration, receipt of which is hereby acknowledged, the Assignor does hereby assign to Assignee all rights, title and interest in and to the mark described herein, together with the good will of the business symbolized by such mark, in the above identified registration thereof.

[ASSIGNOR]

Executed this: 02-22-2016

By: AU MERROW CORPORATION

OWNER Name: Jianhua Zhu

Signature: 

## ASSIGNMENT OF PATENT

Whereas, Jianhua Zhu (As Known as: Mandy Wang) who's the owner of AU MERROW CORPORATION (Assignor), has used and is using a mark which is registered in the United States Patent and Trademark Office, Registration No. 4117691 dated Mar. 27, 2012. Which mark is known as Black Rainn by Daniel Rainn.

Whereas, Mandy Wang (Formerly Known as: Jianhua Zhu) who's the owner of ZZ Fashion Corporation (Assignee), desires to acquire such mark and the registration thereof:

Now, Therefore, for good and valuable consideration, receipt of which is hereby acknowledged, the Assignor does hereby assign to Assignee all rights, title and interest in and to the mark described herein, together with the good will of the business symbolized by such mark, in the above identified registration thereof.

[ASSIGNOR]

Executed this: 02-22-2016

By: AU MERROW CORPORATION

OWNER Name: Jianhua Zhu

Signature: 

## ASSIGNMENT OF PATENT

Whereas, Jianhua Zhu (As Known as: Mandy Wang) who's the owner of AU MERROW CORPORATION (Assignor), has used and is using a mark which is registered in the United States Patent and Trademark Office, Registration No. 4028693 dated Sep. 20, 2011. Which mark is known as pale sky.

Whereas, Mandy Wang (Formerly Known as: Jianhua Zhu) who's the owner of ZZ Fashion Corporation (Assignee), desires to acquire such mark and the registration thereof:

Now, Therefore, for good and valuable consideration, receipt of which is hereby acknowledged, the Assignor does hereby assign to Assignee all rights, title and interest in and to the mark described herein, together with the good will of the business symbolized by such mark, in the above identified registration thereof.

[ASSIGNOR]

Executed this: 02-22-2016

By: AU MERROW CORPORATION

OWNER Name: Jianhua Zhu

Signature: 

ZZ FASHION CORP  
 7210 Dominion Circle  
 LOS ANGELES, CA 900403647  
 United States  
 Tet (213) 627-8861 EXT 306 Fax: (213)  
 627-8865  
 DUNS 07-855-3896  
 www.danielrainn.com

<b>Consolidated Invoice</b>	<b>Date</b>
<b>470093</b>	<b>12/08/2015</b>

Please remit payment to:  
 ZZ FASHION CORP  
 7210 Dominion Circle  
 Commerce CA 90040  
 United States

<b>Bill to:</b> NORDSTROM P.O BOX 870 SEATTLE WA 98111 United States	<b>Ship to:</b> Store: 399 NORDSTROM DC #399 1600 S. MILLIKEN ONTARIO CA 91761-7812 United States
--	---

Acct	Order	Dept.	Terms	Division	Rep1	Rep2	Purchase Order
NORDS		0164	NET 45	ALL	012	031	21345900
Phone		Ship Via	Bill of Lading				
		CTE	08464810000043996				
Vendor				Approval			
0005075537							

Style	Description	MPTC	Total Units	Price	Total Amt.
13899PR1	(a) XS S M L XL XXL				
13899PR1	(ANTIV) LaceShldr CrpSlv Vnk-ANTIQUE IVORY (a) 90 103 83 65		341	14.50	4,944.50
13899PR1	(POPPY) LaceShldr CrpSlv Vnk-POPPY (a) 88 105 85 66		344	14.50	4,988.00
13899PR1	(BLK) LaceShldr CrpSlv Vnk-BLACK (a) 88 106 85 64		343	14.50	4,973.50
<b>Merchandise</b>			<b>1028</b>		<b>14,906.00</b>



**Due Date: 01/22/2016**  
**Total Charges: 14,906.00**  
**Pay/Adjustments -14,906.00**

Pick Ticket	Ship Date	No. Ctns.	Weight	Start	Complete	Invoice	Pay This Amt. USD
876631	12/08/2015	44	41.00	12/04/2015	12/10/2015	470093	0.00

Customer Copy

**TRADEMARK**  
**REEL: 005739 FRAME: 0207**

DANIEL RAINN  
 7210 Dominion Circle  
 LOS ANGELES, CA 900403647  
 United States  
 Tel (213) 627-8861 EXT 306 Fax: (213)  
 627-8865  
 DUNS 07-855-3896  
 www.danielrainn.com

<b>Consolidated Invoice</b>	<b>Date</b>
<b>438994</b>	<b>11/05/2014</b>

Please remit payment to:  
 ZZ FASHION CORP  
 7210 Dominion Circle  
 Commerce CA 90040  
 United States

<b>Bill to:</b> NORDSTROM P.O BOX 870 SEATTLE WA 98111 United States	<b>Ship to: Store: 299</b> NORDSTROM DC#299 5050 CHAVENELLE RD. DUBUQUE IA 52002-2616 United States
--	---

Acct	Order	Dept.	Terms	Division	Rep1	Rep2	Purchase Order
NORDS		0149	NET 45	DR	012		15458691
Phone			Ship Via	Bill of Lading			
			CTE	0846481000028597			
Vendor					Approval		
0005075537							

Style	Description	MPTC	Total Units	Price	Total Amt.
X14068RY1	(a) 1X 2X 3X 0X 4X				
X14068RY1	(EGR) BtnOver SoldBk-EARL GREY (a) 145 95 57		297	13.80	4,098.60
X14068RY1	(7003) BtnOver SoldBk-7003 BLACK (a) 108 71 44		223	13.80	3,077.40
X14068RY1	(DPREDBtnOver SoldBk-DEEP RED (a) 79 51 35		165	13.80	2,277.00
X14266PG1	(a) 1X 2X 3X 0X 4X				
X14266PG1	(7720B) L/S Tie Neck-7720 BLACK (a) 111 73 47		231	14.37	3,319.47
X14407PR1	(a) 1X 2X 3X 0X 4X				
X14407PR1	(BLK) PatternSide CropSlv-BLACK (a) 59 38 25		122	15.52	1,893.44
X14414RY1	(a) 1X 2X 3X 0X 4X				
X14414RY1	(BLK) LaceShldrn S/S-BLACK (a) 59 38 25		122	14.37	1,753.14
X14414RY1	(IVO) LaceShldrn S/S-IVORY (a) 59 38 25		122	14.37	1,753.14

<b>Due Date:</b> 12/20/2014
<b>Total Charges:</b> 30,725.21
<b>Pay/Adjustments</b> -30,725.21

Pick Ticket	Ship Date	No. Ctns.	Weight	Start	Complete	Invoice	Pay This Amt. USD
842952	11/05/2014	51	35.00	10/30/2014	11/04/2014	438994	0.00

Customer Copy

**TRADEMARK**  
**REEL: 005739 FRAME: 0208**



DANIEL RAINN  
 7210 Dominion Circle  
 LOS ANGELES, CA 900403647  
 United States  
 Tel (213) 627-8861 EXT 306 Fax: (213)  
 627-8865  
 DUNS 07-855-3896  
 www.danielrainn.com

<b>Consolidated Invoice</b>	<b>Date</b>
<b>438994</b>	<b>11/05/2014</b>

Please remit payment to:  
 ZZ FASHION CORP  
 7210 Dominion Circle  
 Commerce CA 90040  
 United States

<b>Bill to:</b> NORDSTROM P.O BOX 870 SEATTLE WA 98111 United States	<b>Ship to:</b> Store: 299 NORDSTROM DC#299 5050 CHAVENELLE RD. DUBUQUE IA 52002-2616 United States
--	---

Acct	Order	Dept.	Terms	Division	Rep1	Rep2	Purchase Order
NORDS		0149	NET 45	DR	012		15458691
Phone		Ship Via		Bill of Lading			
		CTE		08464810000028597			
Vendor					Approval		
0005075537							

Style	Description	MPTC	Total Units	Price	Total Amt.
X14470PR1	(a) 1X 2X 3X 0X 4X				
X14470PR1	(7214) JaggedSharkBite Tk-7214 BLACK (a) 114 73 47		234	14.37	3,362.58
X14782PR1	(a) 1X 2X 3X 0X 4X				
X14782PR1	(ANTIV) SequenceUpper-ANTIQUE IVORY (a) 149 95 88		302	15.52	4,687.04
X30185VB1	(a) 1X 2X 3X 0X 4X				
X30185VB1	(7547) LgLaceBtm BedJkt-7547 BLACK (a) 81 50 47		178	25.30	4,503.40
<b>Merchandise</b>			<b>1996</b>		<b>30,725.21</b>

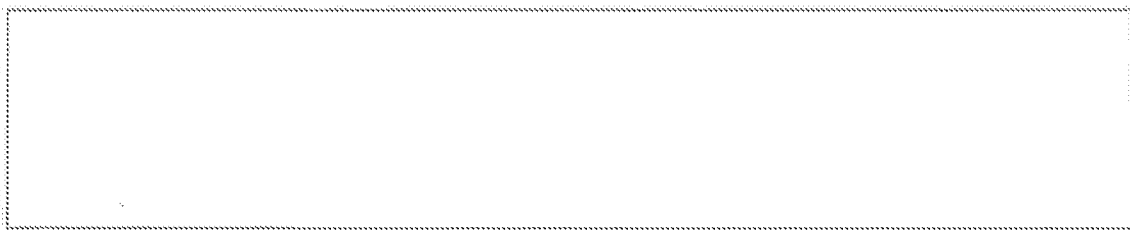

**Due Date: 12/20/2014**  
**Total Charges: 30,725.21**  
**Pay/Adjustments -30,725.21**

Pick Ticket	Ship Date	No. Ctns.	Weight	Start	Complete	Invoice	Pay This Amt. USD
842952	11/05/2014	51	35.00	10/30/2014	11/04/2014	438994	0.00

Customer Copy

**TRADEMARK**  
**REEL: 005739 FRAME: 0209**

# Rack Plus 11/6-11/11/14

Rita Teo: 5,361 pcs/ \$85,935.03

# Daniel Raim

OC # 1790698

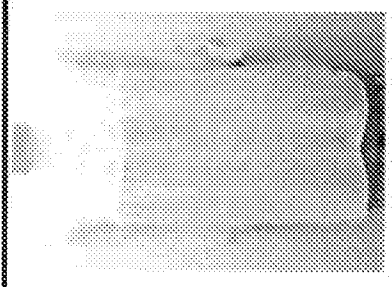
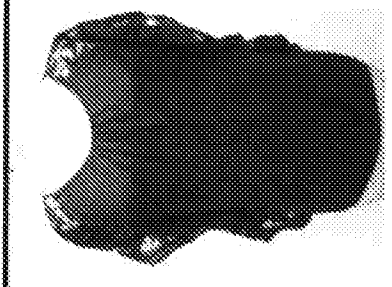
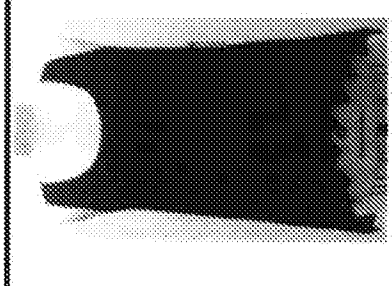
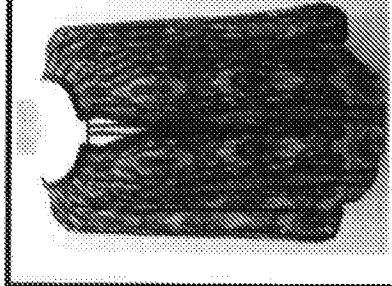
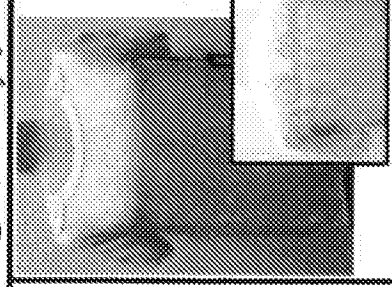
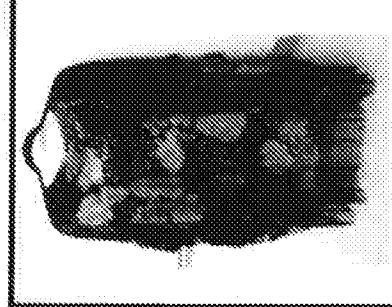
					
<p>X14782PRI-Antiq Ivory</p> <p>1,210 pcs</p> <p>1x/581-387-242</p>	<p>X14407PRI-Black</p> <p>497 pcs</p> <p>1x/239-15-99</p> <p>1x / 239-15-99</p>	<p>X14470PRI</p> <p>7214 Black 426 923 pcs x/444-297-185</p> <p>1x / 444-297-185</p>	<p>X14266PGI</p> <p>7720B Black Black Binding 925 pcs 1x/444-296-185</p>	<p>X14414RY1</p> <p>Ivory 497 pcs 1x/239-15-99</p> <p>Black 497 pcs 1x/239-15-99</p>	<p>X30185VBI-7547 Black</p> <p>810 pcs</p> <p>1x/389-259-162</p>
<p>\$15.52/ \$32.97 Rtl/ \$72 MSRP</p> <p>(Poly pebble crepe. Dim lace. 16L S/B. No cam. Ship rolled slv.)</p>	<p>\$15.52/ \$32.97 Rtl/ \$72 MSRP</p> <p>(Poly pebble crepe. Dim lace &amp; binding. No cam.)</p>	<p>\$14.37/ \$72 Rtl/ \$72 MSRP</p> <p>(Poly pebble crepe. Dim lace and binding. No cam.)</p>	<p>\$14.37/ \$29.97 Rtl/ \$72 MSRP</p> <p>(75d poly egt. Dim binding. Dim 50d knit cam. Ship untied.)</p>	<p>\$14.37/ \$29.97 Rtl/ \$72 MSRP</p> <p>(Rayon Challis. Dim lace. Dim zipper tape, gold zipper. No cam.)</p>	<p>\$25.30/ \$49.97 Rtl/ \$102 MSRP</p> <p>(Velvet burnout. Bik fringe bottom. No lining.)</p>

DANIEL RAINN  
 7210 Dominion Circle  
 LOS ANGELES, CA 900403647  
 United States  
 Tel (213) 627-8861 EXT 306 Fax: (213)  
 627-8865  
 DUNS 07-855-3896  
 www.danielrainn.com

<b>Consolidated Invoice</b>	<b>Date</b>
<b>400285</b>	<b>10/02/2012</b>

Please remit payment to:  
 ZZ FASHION CORP  
 7210 Dominion Circle  
 Commerce CA 90040  
 United States

<b>Bill to:</b> NORDSTROM P.O BOX 870 SEATTLE WA 98111 United States	<b>Ship to:</b> Store: 299 NORDSTROM DC#299 5050 CHAVENELLE RD. DUBUQUE IA 52002-2616 United States
--	---

Acct	Order	Dept.	Terms	Division	Rep1	Rep2	Purchase Order
NORDS		0164	NET 45	DR	012		14366697
Phone	Ship Via		Bill of Lading				
(877) 444-1313	CTE		08464810000000197				
Vendor					Approval		
0005075537							

Style	Description	MPTC	Total Units	Price	Total Amt.
11905NR	(a) XS S M L XL XS/S M/L XXS (b) XXL				
11905NR	(FAWN) BTN UP SCOOP BTM WB-FAWN (a) 68 75 42 27		212	12.00	2,544.00
12189	(a) XS S M L XL XS/S M/L XXS (b) XXL				
12189	(5081) LACE REGLAN SLV BLS-5081 BLUSH/ BLK (a) 94 102 58 35		289	13.50	3,901.50
12288	(a) XS S M L XL XS/S M/L XXS (b) XXL				
12288	(4640B) STPED BUTN UP ROLL SLV-4640 BISQ/ BLK (a) 68 75 42 27		212	11.00	2,332.00
12288	(4918) PKT BUTN UP ROLL SLV-4918 BLK/ BLUSH (a) 68 75 42 27		212	11.00	2,332.00
12288	(BLUSA)PKT BUTN UP ROLL SLV-BLUE SAPPHIRE (a) 138 150 85 57		430	11.00	4,730.00
12288	(CRAN) PKT BUTN UP ROLL SLV-CRANBERRY (a) 92 101 58 38		289	11.00	3,179.00



**Due Date: 11/16/2012**  
**Total Charges: 36,814.50**  
**Pay/Adjustments -36,814.50**

Pick Ticket	Ship Date	No. Ctns.	Weight	Start	Complete	Invoice	Pay This Amt. USD
	10/02/2012	71	70.00	09/27/2012	10/02/2012	400285	0.00

Customer Copy

**TRADEMARK**  
**REEL: 005739 FRAME: 0211**

DANIEL RAINN  
 7210 Dominion Circle  
 LOS ANGELES, CA 900403647  
 United States  
 Tel (213) 627-8861 EXT 306 Fax: (213)  
 627-8865  
 DUNS 07-855-3896  
 www.danielrainn.com

<b>Consolidated Invoice</b>	<b>Date</b>
<b>400285</b>	<b>10/02/2012</b>

Please remit payment to:  
 ZZ FASHION CORP  
 7210 Dominion Circle  
 Commerce CA 90040  
 United States

<b>Bill to:</b> NORDSTROM P.O BOX 870 SEATTLE WA 98111 United States	<b>Ship to:</b> Store: 299 NORDSTROM DC#299 5050 CHAVENELLE RD. DUBUQUE IA 52002-2616 United States
--	---

Acct	Order	Dept.	Terms	Division	Rep1	Rep2	Purchase Order
NORDS		0164	NET 45	DR	012		14366697
Phone	Ship Via		Bill of Lading				
(877) 444-1313	CTE		08464810000000197				
Vendor					Approval		
0005075537							

Style	Description	MPTC	Total Units	Price	Total Amt.
12288	(a) XS S M L XL (b) XXL	XS/S	M/L	XXS	
12288	(EGR) PKT BUTN UP ROLL SLV-EARL GREY (a) 93 102 59 39		293	11.00	3,223.00
12317	(a) XS S M L XL (b) XXL	XS/S	M/L	XXS	
12317	(BLUSHLNG SLV BNDED WST-BLUSH (a) 68 75 47 27		217	13.50	2,929.50
12449	(a) XS S M L XL (b) XXL	XS/S	M/L	XXS	
12449	(BLK) BEAD COLLAR BUTON UP-BLACK (a) 95 102 59 38		294	14.50	4,263.00
12449	(BLUSHBEAD COLLAR BUTON UP-BLUSH (a) 97 102 59 38		296	14.50	4,292.00
12450	(a) XS S M L XL (b) XXL	XS/S	M/L	XXS	
12450	(BLK) PETER PAN COLAR TUNC-BLACK (a) 67 77 42 27		213	14.50	3,088.50

--	--	--	--	--	--	--	--

**Due Date: 11/16/2012**  
**Total Charges: 36,814.50**  
**Pay/Adjustments -36,814.50**

Pick Ticket	Ship Date	No. Ctns.	Weight	Start	Complete	Invoice	Pay This Amt. USD
	10/02/2012	71	70.00	09/27/2012	10/02/2012	400285	0.00

Customer Copy

**TRADEMARK**  
**REEL: 005739 FRAME: 0212**

DANIEL RAINN  
 7210 Dominion Circle  
 LOS ANGELES, CA 900403647  
 United States  
 Tel (213) 627-8861 EXT 306 Fax: (213)  
 627-8865  
 DUNS 07-855-3896  
 www.danielrainn.com

<b>Consolidated Invoice</b>	<b>Date</b>
<b>400285</b>	<b>10/02/2012</b>

Please remit payment to:  
 ZZ FASHION CORP  
 7210 Dominion Circle  
 Commerce CA 90040  
 United States

Bill to: NORDSTROM P.O BOX 870 SEATTLE WA 98111 United States	Ship to:      Store: 299 NORDSTROM DC#299 5050 CHAVENELLE RD. DUBUQUE IA 52002-2616 United States
---	---

Acct	Order	Dept.	Terms	Division	Rep1	Rep2	Purchase Order
NORDS		0164	NET 45	DR	012		14366697
Phone	Ship Via		Bill of Lading				
(877) 444-1313	CTE		08464810000000197				
Vendor					Approval		
0005075537							

Style	Description	MPTC	Total Units	Price	Total Amt.
	<b>Merchandise</b>		<b>2957</b>		<b>36,814.50</b>

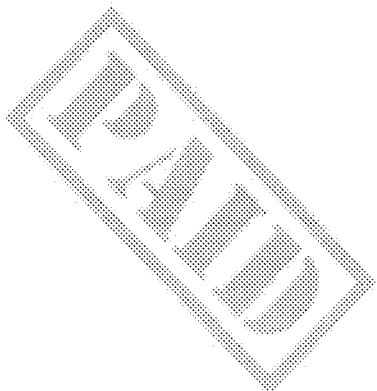

--	--	--	--	--	--	--	--

**Due Date: 11/16/2012**  
**Total Charges: 36,814.50**  
**Pay/Adjustments -36,814.50**

Pick Ticket	Ship Date	No. Ctns.	Weight	Start	Complete	Invoice	Pay This Amt.	USD
	10/02/2012	71	70.00	09/27/2012	10/02/2012	400285		0.00

Customer Copy

**TRADEMARK**  
**REEL: 005739 FRAME: 0213**

ZZ FASHION CORP  
 7210 Dominion Circle  
 LOS ANGELES, CA 900403647  
 United States  
 Tet (213) 627-8861 EXT 306 Fax: (213)  
 627-8865  
 DUNS 07-855-3896  
 www.danielrainn.com

<b>Invoice</b>	<b>Date</b>
<b>471444</b>	<b>01/13/2016</b>

Please remit payment to:  
 ZZ FASHION CORP  
 7210 Dominion Circle  
 Commerce CA 90040  
 United States

<b>Bill to:</b> TJX COMPANIES SHARED SERVICES IMPORTS PAYABLE 770 COCHITUATE ROAD 500-A2 FRAMINGHAM MA 01701 United States	<b>Ship to:</b> Store: 893 TJ MAXX PITTSTON DC 893 4000 Oldfield Blvd. Pittston PA 18640 United States
---	---

Acct	Order	Dept.	Terms	Division	Rep1	Rep2	Purchase Order
MARMA	213878	30	NET 30	*AnyDivision	012	031	30963597
Phone	Ship Via		Bill of Lading				
(213) 599-4603	NRT		08464810000044986				
Vendor					Approval		
47169							

Style	Description	MPTC	Total Units	Price	Total Amt.
50349PR1PK	(a) CASE				
50349PR1PK	(9927) TieWst 3/4 Sly Drs-9927 BLACK (a) 501		501	79.50	39,829.50
50390PR1PK	(a) CASE				
50390PR1PK	(MAJESBtl nFmt Roll Tab L/s-MAJESTIC BLUE (a) 591		591	79.50	46,984.50
50513PR1PK	(a) CASE				
50513PR1PK	(6715) 3/4 Sly Shirt Dress-6715 BLUE (a) 484		484	82.50	39,930.00
50570PR1PPK	(a) CASE				
50570PR1PPK	(BLK) Shidr Detail Shift-BLACK (a) 400		400	79.50	31,800.00
<b>Merchandise</b>			<b>1976</b>		<b>158,544.00</b>

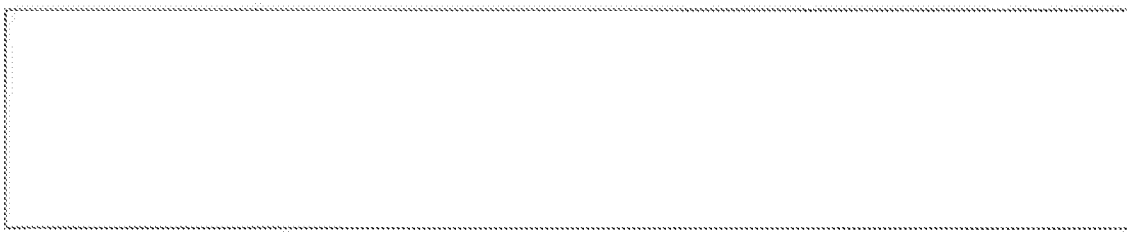

**Due Date: 02/12/2016**  
**Total Charges: 158,544.00**  
**Pay/Adjustments -158,544.00**

Pick Ticket	Ship Date	No. Ctns.	Weight	Start	Complete	Invoice	Pay This Amt USD
878417	01/13/2016	1976	7,904.00	01/05/2016	01/15/2016	471444	0.00

Customer Copy

**TRADEMARK**  
**REEL: 005739 FRAME: 0214**

ZZ FASHION CORP  
 7210 Dominion Circle  
 Commerce CA 90040  
 United States  
 Tel: (213) 627-8861 EXT 306 Fax: (213)  
 DUNS 07-855-3896  
 www.danielrainn.com

Invoice	Date
<b>429185</b>	<b>06/03/2014</b>

Please remit payment to:  
 ZZ FASHION CORP  
 7210 Dominion Circle  
 Commerce CA 90040  
 United States

Bill To: <b>MARSHALLS</b> <b>SHARED SERVICES IMPORTS PAYABLE</b> <b>770 COCHITUATE ROAD, 500-A2</b> <b>FRAMINGHAM MA 01701</b> <b>United States</b>	Ship to: Store <b>881</b> <b>MARSHALLS/AZR: MAR PHOENIX</b> <b>DC# 881</b> <b>3000 S. 55TH AVENUE</b> <b>PHOENIX, AZ 85043</b> <b>United States</b>
--	--



Acct	Purchase Order	Dept.	Terms	Rep1	Rep2	Ship Via	Order	Approval	
MARSH	01 382894	01	NET 60	012		NRT	167063		
Phone		Vendor	Bill of Lading		Division				
(213) 599-4603		1577744	5302054579						
Style	Description					Total Units	Price	Total Amt.	
14232PC1	XS S M L XL								
14232PC1	(6525A) S/S Crew Neck 6525 ANTIQUE IVORY	139	280	260	141	840	8.93	7,501.20	
14232PC1	(7324B) S/S Crew Neck 7324 BLACK	191	366	367	197	1181	8.93	10,367.73	
<b>Merchandise</b>						<b>2001</b>		<b>17,868.93</b>	



Due Date **08/02/2014**  
 Total Charges **17,868.93**

Pick Ticket	Ship Date	No. Ctns.	Weight	Start	Complete	Invoice	Pay This Amt.	USD
833067	06/03/2014	22	528	05/20/2014	05/30/2014	429185		<b>17,868.93</b>

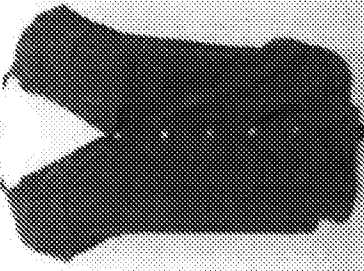
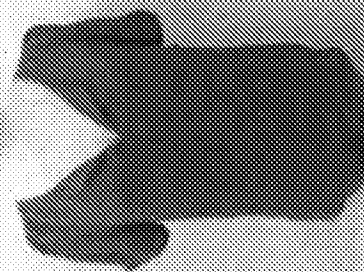
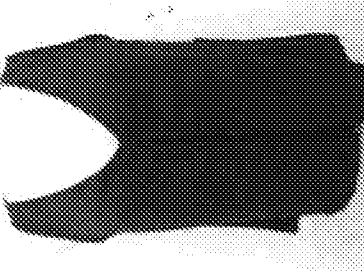
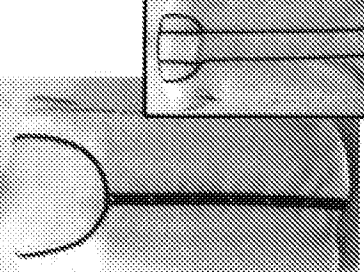
Customer Copy

				
<p>12908 12908PRI-Passion 1,000 pcs</p>	<p>12813 12813PRI-5639 Antq Ivory 420 pcs*</p>	<p>13678 13678PCI-7328 Bk 1,200 pcs</p>	<p>12736 12736PCI-5111 Blue w/ Bk binding Nickle Btm 1,000 pcs*</p>	<p>14257 14257PD2-Antq Ivry 1,000 pcs</p>
<p>12908PRI-Indigo 1,000 pcs</p>	<p>12813PCI-7326 Black 1,200 pcs</p>	<p>13678PCI-7325T Tangerine 1,200 pcs</p>	<p>12736PRI-Maj Blue w/ Bk binding Nickle Btm 1,000 pcs</p>	<p>14257PD2-Black 1,000 pcs</p>
<p>12813PRI-Tangerine 1,000 pcs</p>	<p>13678PRI-Passion 1,000 pcs</p>	<p>13678PRI-Black 1,000 pcs</p>		
<p>12813PRI-Blue Turq 1,000 pcs</p>				
<p>\$9.18 (16L S/B, No cami.)</p>	<p>\$8.93 (No cami.)</p>	<p>\$8.83 (No cami.)</p>	<p>\$8.43 (Binding as above. Btm B-120 as above. No cami.)</p>	<p>\$9.68 (Ref. 14021, no lace back. No cami.)</p>



ZZ FASHION CORP  
 7210 Dominion Circle  
 Commerce, CA 90040  
 United States  
 Tel: (213) 627-8861 EXT 306 Fax: (213)  
 627-8865  
 DUNS 07-855-3896  
 www.danielrainn.com

Invoice	Date
429961	06/09/2014

Please remit payment to:  
 ZZ FASHION CORP  
 7210 Dominion Circle  
 Commerce CA 90040  
 United States

Bill to: TJX CANADA ATT: ACCOUNTS PAYABLE 6715 AIRPORT ROAD MISSISSAUGA ON L4V- 1Y2 Canada	Ship to: Store: 891 TJX CANADA DC# 891 55 West Drive Brampton ON L6T 4A1 Canada
---	---

Acct	Purchase Order	Dept	Terms	Rep1	Rep2	Ship Via	Order
WINNE	10 435851	10	NET 60	000		ABF FREIGHT SYS	163884
Phone	Vendor					Division	
(213) 599-4653						*AnyDivision	
Approval							

Style	Description	MPTC	Total Units	Price	Total Amt
90075GB2	(a) XS S M L XL XS/S M/L				
90075GB2	(BLF40) PmtLnd RollStv Bizr-BLACK w/6140 LINING		1,080	14.25	15,390.00
	(a) 360 360 360				
90100PR1	(a) XS S M L XL XS/S M/L				
90100PR1	(48270) DrwStrg 1Pckt JK-4827 OLIVE		1,071	14.50	15,523.50
	(a) 358 359 356				
<b>Merchandise</b>			<b>2151</b>		<b>30,919.50</b>

--

Due Date: 08/08/2014  
 Total Charges: 30,919.50  
 Pay/Adjustments -30,919.50

Pick Ticket	Ship Date	No. Ctns.	Weight	Start	Complete	Invoice	Pay This Amt. USD
834233	06/09/2014	60	780.00	05/16/2014	05/30/2014	429961	0.00

Customer Copy

**TRADEMARK**  
**REEL: 005739 FRAME: 0217**

**TJX Canada 5/30/14 FOB**

6,000 pcs/ \$34,000.00

**Jackets**

**Daniel Raim**

Ex: China

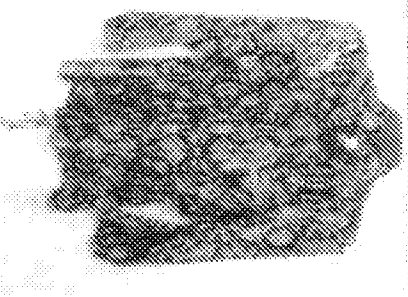
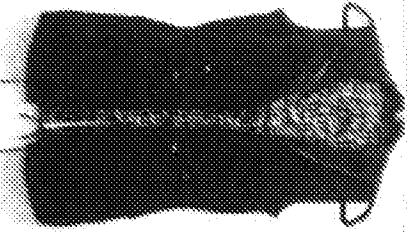
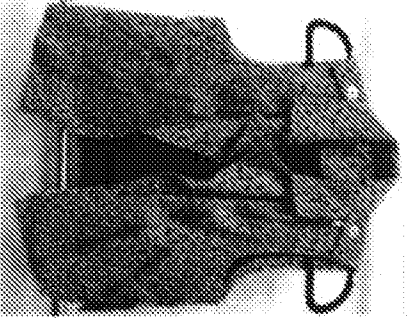
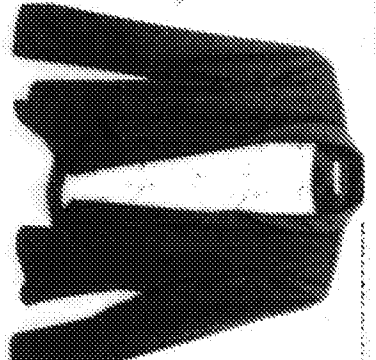
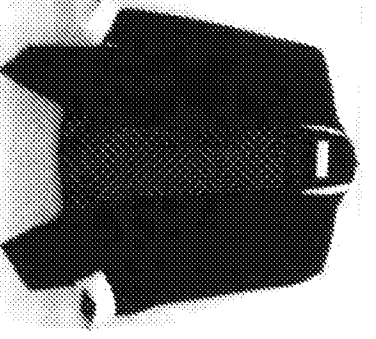
				
<p>30100PR1-48270 Olive 1,200 pcs \$14.50 (Poly pebble crepe. Self pebble crepe draw string. Antq brass hardware. No lining.)</p>	<p>30166PR1-Black (Ref: 30111 w/ lining.) Lining: <del>228</del> Blk 7345 1,200 pcs \$14.00 (Poly pebble crepe. Self pebble crepe draw string. Antq brass hardware. Printed woven lining.)</p>	<p>30101WV1-6812 Pewter 1,200 pcs \$13.00 (Heavy woven jacket fabric. Antq nickel hardware. Black woven lining.)</p>	<p>12154WV1-Gun Metal Lining: 4733 Ivy 1,200 pcs \$14.25 (Woven novelty. Shoulder pad. Lined back with printed woven lining.)</p>	<p>300075GB2-Black Lining: 6140 Black 1,200 pcs \$14.25 (Smooth gab. Winter white contrast. Dull saffron lining. Ship rolled sleeve once to winter white. As picture.)</p>

TRADEMARK

REEL 006739 FRAME 0218

DANIEL RAINN  
 7210 Dominion Circle  
 LOS ANGELES, CA 900403647  
 United States  
 Tel (213) 627-8861 EXT 306 Fax: (213)  
 627-8865  
 DUNS 07-855-3896  
 www.danielrainn.com

Invoice	Date
402173	12/18/2012

Please remit payment to:  
 ZZ FASHION CORP  
 7210 Dominion Circle  
 Commerce CA 90040  
 United States

Bill to: TJX COMPANIES SHARED SERVICES IMPORTS PAYABLE 770 COCHITUATE ROAD 500-A2 FRAMINGHAM MA 01701 United States	Ship to: Store: 893 TJ MAXX PITTSTON DC 893 4000 Oldfield Blvd. Pittston PA 18640 United States
--	--

Acct	Order	Dept.	Terms	Division	Rep1	Rep2	Purchase Order
MARMA	134444	3	40 EOM	DR	006		30088522
Phone	Ship Via		Bill of Lading				
(508) 390-3407	NRT		08464810000001729				
Vendor					Approval		
2C490							

Style	Description	MPTC	Total Units	Price	Total Amt.
11892PPK	(a) CASE				
11892PPK	(5042) SCOOP NK PULOVR WB-5042 BLU/ GRN		205	54.00	11,070.00
	(a) 205				
					CODE: E
11909PPK	(a) CASE				
11909PPK	(BLK) Flutter frnt hny tank-SLACK		188	48.00	9,024.00
	(a) 188				
					CODE: G
12402PPK	(a) CASE				
12402PPK	(GRN) Tie waist buton up-GREEN		188	54.60	10,264.80
	(a) 188				
					CODE: G
12546PPK	(a) CASE				
12546PPK	(IVOID) Rnd nk cntrst slv shrt-ANTI IVORY/ INDIGO		188	51.00	9,588.00
	(a) 188				
					CODE: G
12585PPK	(a) CASE				



Due Date: 12/19/2012  
 Total Charges: 52,861.80  
 Pay/Adjustments -52,861.80

Pick Ticket	Ship Date	No. Ctns.	Weight	Start	Complete	Invoice	Pay This Amt. USD
801799	12/17/2012	393	1.00	11/20/2012	11/30/2012	402173	0.00

Customer Copy

**TRADEMARK**  
 REEL: 005739 FRAME: 0219

DANIEL RAINN  
 7210 Dominion Circle  
 LOS ANGELES, CA 900403647  
 United States  
 Tel (213) 627-8861 EXT 306 Fax: (213)  
 627-8865  
 DUNS 07-855-3896  
 www.danielrainn.com

Invoice	Date
402173	12/18/2012

Please remit payment to:  
 ZZ FASHION CORP  
 7210 Dominion Circle  
 Commerce CA 90040  
 United States

Bill to: TJX COMPANIES SHARED SERVICES IMPORTS PAYABLE 770 COCHITUATE ROAD 500-A2 FRAMINGHAM MA 01701 United States	Ship to:      Store: 893 TJ MAXX PITTSTON DC 893 4000 Oldfield Blvd. Pittston PA 18640 United States
--	---

Acct	Order	Dept.	Terms	Division	Rep1	Rep2	Purchase Order
MARMA	134444	3	40 EOM	DR	006		30088522
Phone	Ship Via		Bill of Lading				
(508) 390-3407	NRT		08464810000001729				
Vendor					Approval		
2C490							

Style	Description	MPTC	Total Units	Price	Total Amt.
12585PPK	(a) CASE				
12585PPK	(4154N) Smk wst hlf blson slv-4154 NAVY/ IVO		205	63.00	12,915.00
	(a) 205				
CODE: E					
<b>Merchandise</b>			<b>974</b>		<b>52,861.80</b>

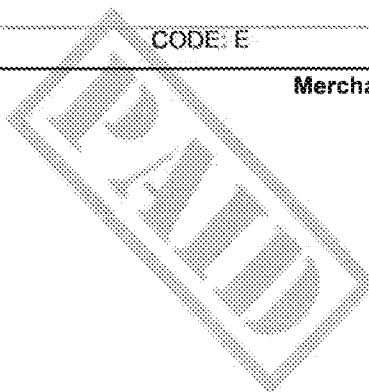

--

Due Date: 12/19/2012  
 Total Charges: 52,861.80  
 Pay/Adjustments -52,861.80

Pick Ticket	Ship Date	No. Ctns.	Weight	Start	Complete	Invoice	Pay This Amt.	USD
801799	12/17/2012	393	1.00	11/20/2012	11/30/2012	402173		0.00

Customer Copy

**TRADEMARK**  
**REEL: 005739 FRAME: 0220**

DANIEL RAINN  
 7210 Dominion Circle  
 LOS ANGELES, CA 900403647  
 United States  
 Tel (213) 627-8861 EXT 306 Fax: (213)  
 627-8865  
 DUNS 07-855-3896  
 www.danielrainn.com

<b>Invoice</b>	<b>Date</b>
<b>473073</b>	<b>02/03/2016</b>

Please remit payment to:  
 ZZ FASHION CORP  
 7210 Dominion Circle  
 Commerce CA 90040  
 United States

<b>Bill to:</b> BLOOMINGDALES  United States	<b>Ship to:</b> Store: 0135 BLOOMINGDALES.COM C/O West Johnson Bloomingdale's Logistic 181 West Johnson Avenue Cheshire CT 06410 United States
---	---

Acct	Order	Dept.	Terms	Division	Rep1	Rep2	Purchase Order
BLOOM	220964	0111	8/10 EOM	DR	030	004	5125348
Phone	Ship Via		Bill of Lading				
(212) 705-5747	NRT		08464810000045662				
Vendor					Approval		
0785538960							

Style	Description	MPTC	Total Units	Price	Total Amt.
D15009PR1	(a) XS S M L XL XXL				
D15009PR1	(9466) V Neck 3/4 Slv Top-9466 INDIGO		50	28.00	1,400.00
	(a) 5 10 13 11 11				
D15302RY3	(a) XS S M L XL XXL				
D15302RY3	(ANTIV) Slvless Top-ANTIQUE IVORY		45	28.00	1,260.00
	(a) 5 9 11 10 10				
D15428PG4	(a) XS S M L XL XXL				
D15428PG4	(9516) Slvless Top-9516 BLUE		40	28.00	1,120.00
	(a) 4 9 10 8 9				
D15684PYN	(a) XS S M L XL XS/S M/L XXS				
	(b) XXL				
D15684PYN	(9180) Binding Tie Frt-9180 BLUE		35	27.00	945.00
	(a) 4 7 9 7 8				
D50753PR1	(a) XS S M L XL XXL				
D50753PR1	(9499) L/S Tie Frt Top-9499 INDIGO		45	30.00	1,350.00
	(a) 5 8 12 10 10				
<b>Merchandise</b>			<b>215</b>		<b>6,075.00</b>

**Due Date: 03/10/2016**  
**Total Charges: 6,075.00**  
**Pay/Adjustments 0.00**

Pick Ticket	Ship Date	No. Ctns.	Weight	Start	Complete	Invoice	Pay This Amt.
880750	01/29/2016	5	124.00	02/01/2016	02/03/2016	473073	USD 6,075.00

Customer Copy

TRADEMARK

REEL: 005739 FRAME: 0221

DANIEL RAINN  
 7210 Dominion Circle  
 LOS ANGELES, CA 900403647  
 United States  
 Tel (213) 627-8861 EXT 306 Fax: (213)  
 627-8865  
 DUNS 07-855-3896  
 www.danielrainn.com

<b>Invoice</b>	<b>Date</b>
<b>466918</b>	<b>11/03/2015</b>

Please remit payment to:  
 ZZ FASHION CORP  
 7210 Dominion Circle  
 Commerce CA 90040  
 United States

<b>Bill to:</b> BLOOMINGDALES  United States	<b>Ship to:</b> Store: 0135 BLOOMINGDALES.COM C/O West Johnson Bloomingdale's Logistic 181 West Johnson Avenue Cheshire CT 06410
---	--

Acct	Order	Dept.	Terms	Division	Rep1	Rep2	Purchase Order
BLOOM	212052	0111	8/10 EOM	DR	030	004	6392038
Phone	Ship Via		Bill of Lading				
(212) 705-5747	FedEx Ground Collect		08464810000042609				
Vendor					Approval		
0785538960							

Style	Description	MPTC	Total Units	Price	Total Amt.
D14416RY3	(a) XS S M L XL (b) XXL	XS/S	M/L	XXS	
D14416RY3	(IVO) OpenCollar L/S-IVORY (a) 3 6 8 6 7		30	27.00	810.00
<b>Merchandise</b>			<b>30</b>		<b>810.00</b>

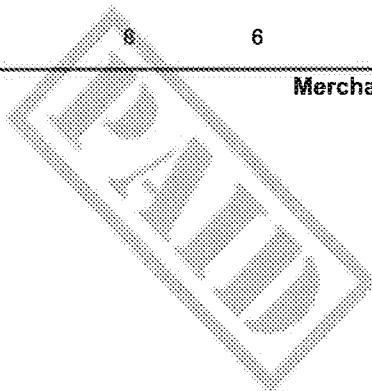

--

**Due Date: 12/10/2015**  
**Total Charges: 810.00**  
**Pay/Adjustments -810.00**

Pick Ticket	Ship Date	No. Ctns.	Weight	Start	Complete	Invoice	Pay This Amt. USD
873183	11/03/2015	1	1.00	11/02/2015	11/04/2015	466918	0.00

Customer Copy

**TRADEMARK**  
**REEL: 005739 FRAME: 0222**

DANIEL RAINN  
 7210 Dominion Circle  
 LOS ANGELES, CA 900403647  
 United States  
 Tel (213) 627-8861 EXT 306 Fax: (213)  
 627-8865  
 DUNS 07-855-3896  
 www.danielrainn.com

Invoice	Date
430895	07/08/2014

Please remit payment to:  
 ZZ FASHION CORP  
 7210 Dominion Circle  
 Commerce CA 90040  
 United States

Bill to: BLOOMINGDALES  United States	Ship to: Store: 0001 BLOOMINGDALES Secaucus DC 500 Meadowlands Pkwy Secaucus NJ 07094 United States
--	--

Acct	Order	Dept.	Terms	Division	Rep1	Rep2	Purchase Order
BLOOM	169041	0111	8/10 EOM	DR	017	004	5752653
Phone	Ship Via		Bill of Lading				
(212) 705-5747	FedEx Ground Collect		08464810000024551				
Vendor					Approval		
0785538960							

Style	Description	MPTC	Total Units	Price	Total Amt.
D12430PY1	(a) XS S M L XL XS/S M/L XXS (b) XXL				
D12430PY1	(5634) Mndrn Hnly QrtSlv-5634 IVORY (a) 5 7 7 5		24	27.00	648.00
D13156PG4	(a) XS S M L XL XS/S M/L XXS (b) XXL				
D13156PG4	(6739) S/S Vnk Long BL-6739 BLUE (a) 6 8 6		29	25.05	726.45
D13729PR1	(a) XS S M L XL XS/S M/L XXS (b) XXL				
D13729PR1	(BLK) LaceTieClrBib Tank-BLACK (a) 5 7 5 4		21	22.80	478.80
D13918PR1	(a) XS S M L XL XS/S M/L XXS (b) XXL				
D13918PR1	(6615) LceStripPanel Slvless-6615 BLACK (a) 5 7 5 4		21	26.80	562.80
D14082PC1	(a) XS S M L XL XS/S M/L XXS (b) XXL				

--

Due Date: 08/10/2014  
 Total Charges: 2,975.25  
 Pay/Adjustments -2,975.25

Pick Ticket	Ship Date	No. Ctns.	Weight	Start	Complete	Invoice	Pay This Amt. USD
834368	07/08/2014	2	1.00	07/04/2014	07/07/2014	430895	0.00

Customer Copy

TRADEMARK  
 REEL: 005739 FRAME: 0223

DANIEL RAINN  
 7210 Dominion Circle  
 LOS ANGELES, CA 900403647  
 United States  
 Tel (213) 627-8861 EXT 306 Fax: (213)  
 627-8865  
 DUNS 07-855-3896  
 www.danielrainn.com

Invoice	Date
430895	07/08/2014

Please remit payment to:  
 ZZ FASHION CORP  
 7210 Dominion Circle  
 Commerce CA 90040  
 United States

Bill to: BLOOMINGDALES  United States	Ship to: Store: 0001 BLOOMINGDALES Secaucus DC 500 Meadowlands Pkwy Secaucus NJ 07094 United States
--	--

Acct	Order	Dept.	Terms	Division	Rep1	Rep2	Purchase Order
BLOOM	169041	0111	8/10 EOM	DR	017	004	5752653
Phone	Ship Via		Bill of Lading				
(212) 705-5747	FedEx Ground Collect		08464810000024551				
Vendor					Approval		
0785538960							

Style	Description	MPTC	Total Units	Price	Total Amt.
D14082PC1	(a) XS S M L XL XS/S M/L XXS (b) XXL				
D14082PC1	(6879) ShrtSlv ScpNk HiLow-6879 IVORY/BLUE (a) 5 6 5		24	23.30	559.20
<b>Merchandise</b>			<b>119</b>		<b>2,975.25</b>

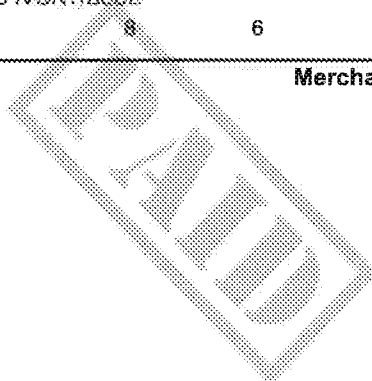

--

**Due Date: 08/10/2014**  
**Total Charges: 2,975.25**  
**Pay/Adjustments -2,975.25**

Pick Ticket	Ship Date	No. Ctns.	Weight	Start	Complete	Invoice	Pay This Amt. USD
834368	07/08/2014	2	1.00	07/04/2014	07/07/2014	430895	0.00

Customer Copy

**TRADEMARK**  
**REEL: 005739 FRAME: 0224**



BLOOMINGDALE'S  
PORTFOLIO

7/4/14 INDC

Daniel Rainn

REP: JASON BECKWITH

REP: AK

TTL U: 762  
TTL \$: \$19,537

*OFF 159911*

\*SHEER STYLES REQUIRE CAMI

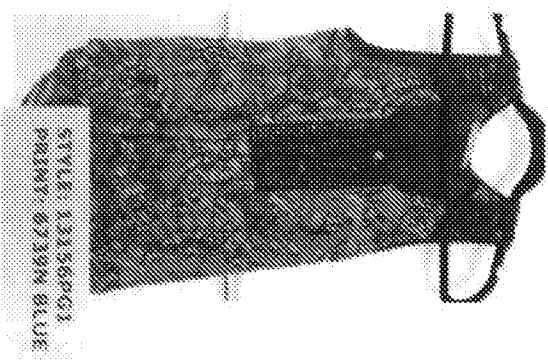
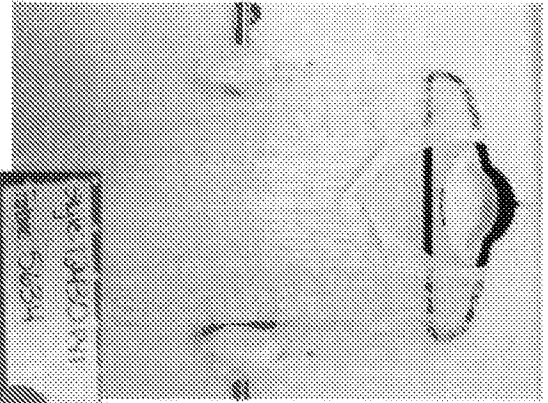
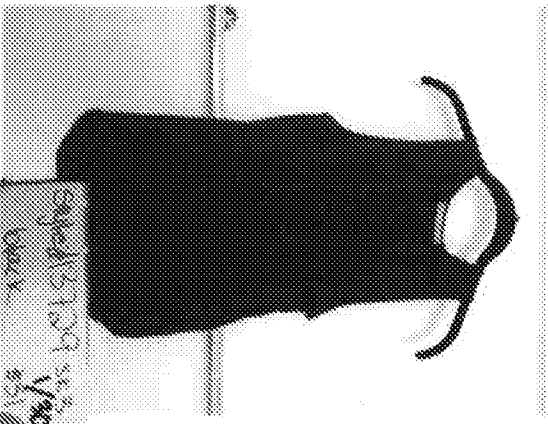
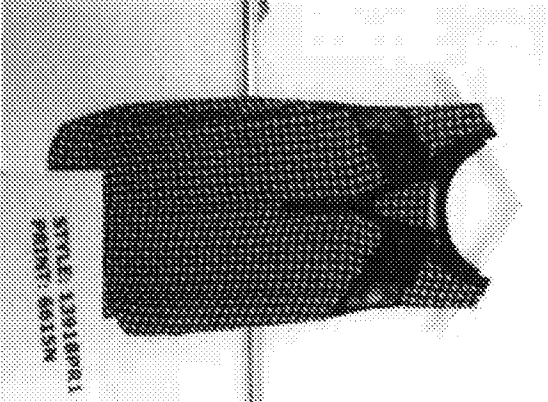
 <p>STYLE: D13156PG4 PRINT: 6739N BLUE</p>		 <p>STYLE: D12430PY1 PRINT: 5634 IVORY</p>		 <p>STYLE: D13729PRI PRINT: BLACK</p>		 <p>STYLE: D13918PRI PRINT: 6615N</p>	
STYLE	D13156PG4	STYLE	D12430PY1	STYLE	D13729PRI	STYLE	D13918PRI
COLOR/PRINT	6739 BLUE	COLOR/PRINT	5634 IVORY	COLOR/PRINT	BLACK	COLOR/PRINT	6615N
FABRIC	PRT POLY GGT	FABRIC	AS-SAMPLE	FABRIC	POLY PEBBLE CREPE	FABRIC	PRT POLY PEBBLE CREPE
SIZE SCALE	S-XL	SIZE SCALE	S-XL	SIZE SCALE	S-XL	SIZE SCALE	S-XL
COST	\$25.05	COST	\$27.00	COST	\$22.80	COST	\$26.80
TTL U	306	TTL U	256	TTL U	100	TTL U	100
TTL \$	\$7,665	TTL \$	\$6,912	TTL \$	\$2,280	TTL \$	\$2,680
NOTES:		NOTES:	WITH CAMI	NOTES:		NOTES:	WITH CAMI